

CAMSO UTV 4S1 FOR SIDE BY SIDE ADJUSTMENTS 2017

1099-00-3328



FORMERLY
CAMOPLAST
SOLIDEAL



FORMERLY
CAMOPLAST
SOLIDEAL

Formerly Camoplast Solideal, Camso is the best of Camoplast and Solideal. To keep moving forward while staying true to our history, we're now Camso, the Road Free Company.

INTRODUCTION

These guidelines are designed to provide you with the information necessary to perform the required adjustments to the system. The right adjustments have a direct impact on performance and life of the system's components. It is important to follow closely the instructions contained in this document in order to make the correct system adjustments and thereby reach optimum system performance.

Follow all the instructions contained in this document. To make sure that every step has been performed, a checklist is provided at the end of the instructions to verify that all the adjustments have been made.

IMPORTANT

The warranty does not apply if the track system was installed by someone other than a Camso dealer or authorized distributor.

IMPORTANT

Verifying your adjustments on the systems is mandatory after the first use of the vehicle; the track tension, alignment and angle of attack of each track system must be re-verified. Incorrect adjustments can decrease the performance of the systems and result in premature wear or breakage of certain components.

IMPORTANT

Before starting the installation, verify that the serial numbers are identical on all 4 track systems. The serial number's last digit (0, 1, 2, 3) indicates the mounting position on the vehicle. Lay out the track systems accordingly. Refer to Figure 1 and Figure 2.

NOTE: If the serial numbers on the track systems do not match, contact your authorized Camso dealer / distributor.

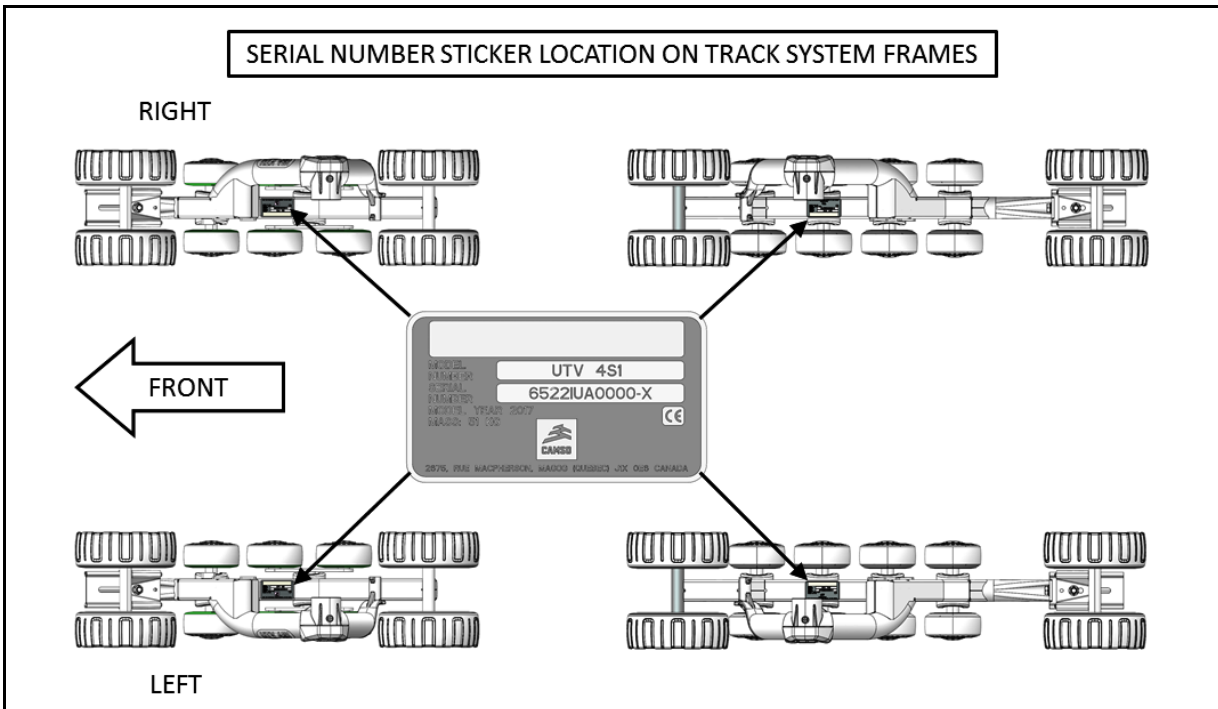

Figure 1

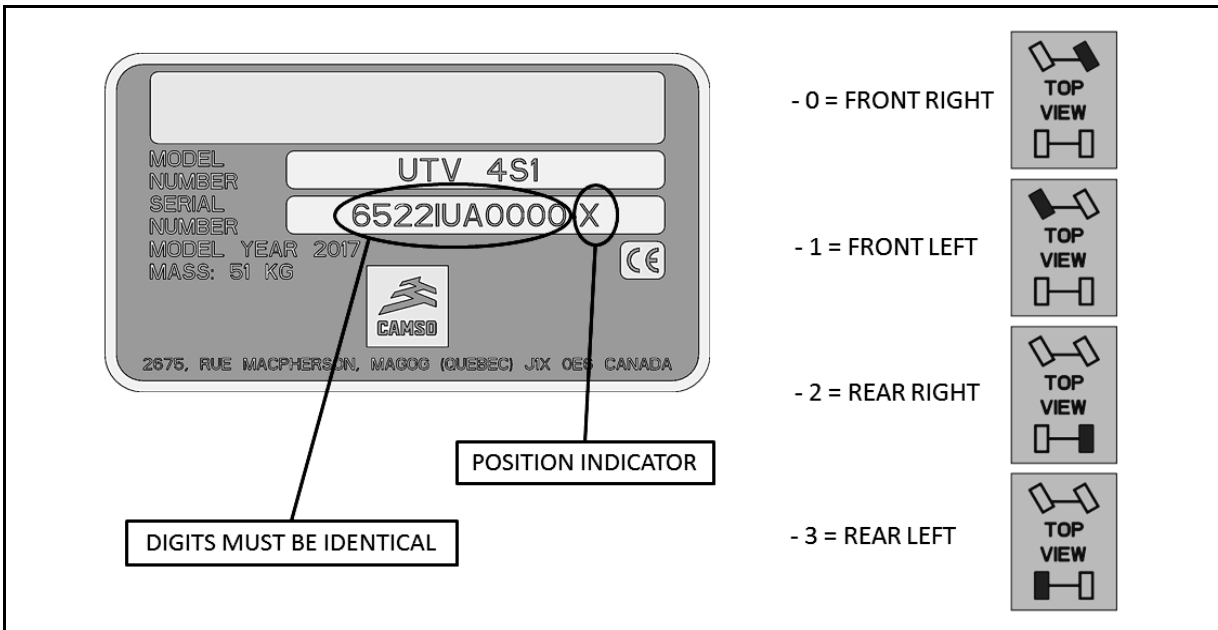

Figure 2

ADJUSTMENTS

NOTE: To make the following adjustments, position the vehicle on a flat and level surface.

ANGLE OF ATTACK - FRONT TRACK SYSTEMS

To obtain the correct angle of attack on front Track Systems, perform the following:

- Orient the steering wheel and the Track Systems straight ahead
- Temporarily apply pressure to the front of the track to make sure that it stays flat on the ground
- Stabilizing arm (1) must be attached to the front anchor bracket (2) installed on the vehicle. See Figure 3.

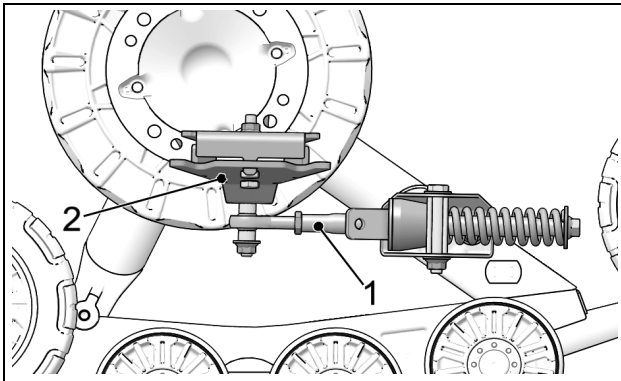

Figure 3

- A Bubble Level is attached to the inside of the front frames. A perfectly centered bubble is needed to adjust the angle of attack correctly. See Figure 4.

NOTE: Before each measurement, temporarily apply light pressure to the front of the track to make sure that it stays flat on the ground.

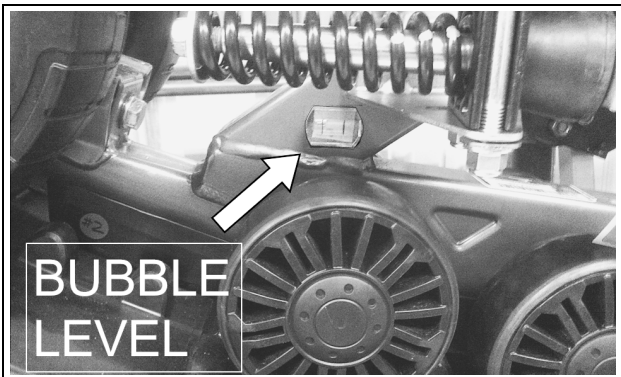

Figure 4

- Loosen anti-rotation bracket bolts (1) and (2) to allow the anti-rotation retainer (3) to rotate freely on its axis. See Figure 5.

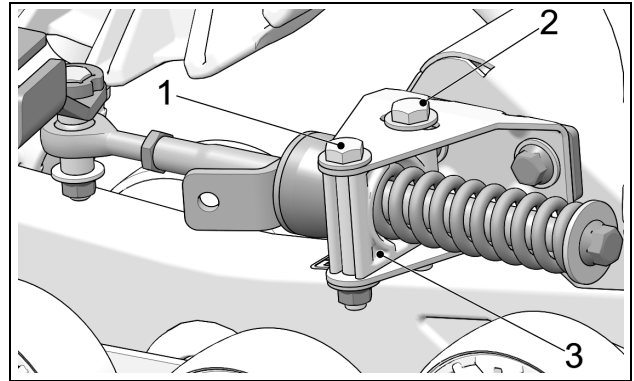

Figure 5

- Loosen jam nut (1). Adjust length of rod end (2) by rotating the steering limiter support plate (3) on the stabilizing arm. Use a 30 mm [1 3/16 in] wrench to rotate support plate to obtain a perfectly centered bubble in the level. Refer to Figure 6.

NOTE: The stabilizing arms on front Track Systems incorporate a steering limiter support plate (3) which is bent. This plate should be positioned inwards, towards the vehicle.

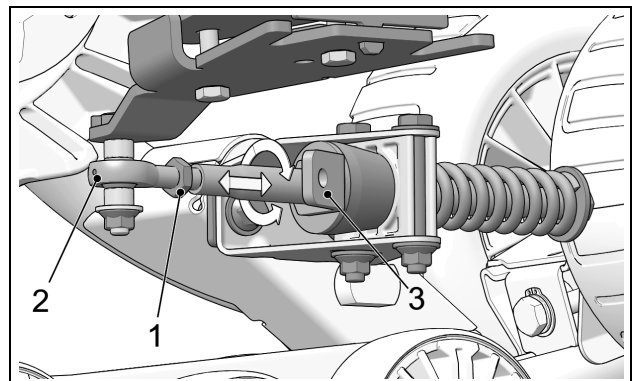

Figure 6

- When angle of attack is correctly set, tighten the jam nut (1) back against the stabilizing arm to 40 N•m [30lb•ft] of torque. See Figure 7.

CAUTION: Follow the recommended torque when tightening the jam nut. Overtightening the nut might damage the rod end.

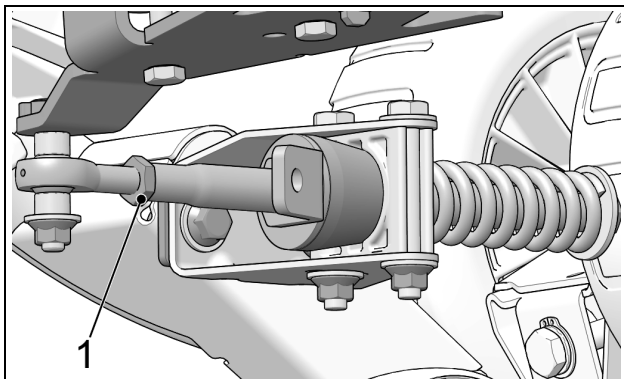

Figure 7

- Re-tighten anti-rotation bracket bolts (1) and (2) to 50 N•m [37 lb•ft] of torque. See Figure 8.

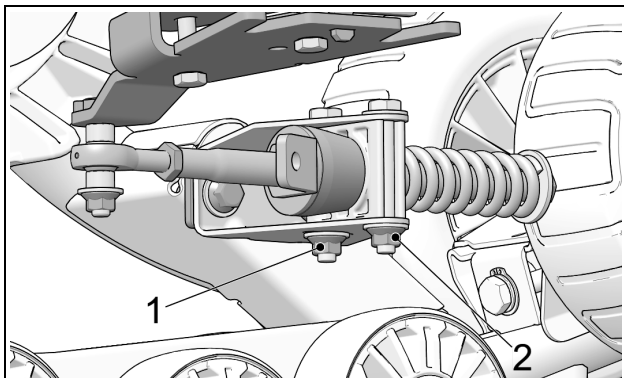

Figure 8

- Once the centered bubble in the level indicates that the angle of attack is correct, double-check the setting by validating the distance from the top of the back tires to the ground.

Position a flat bar on top of the rear wheels of the front Track System and measure from the ground up to the flat bar as shown on Figure 9.

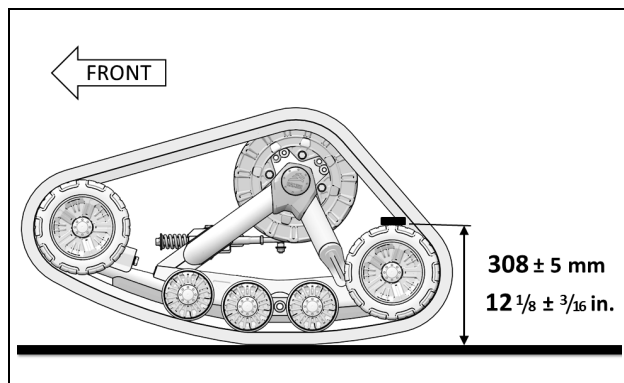

Figure 9

BASIC TUNING (Front Track Systems)

- An adjustment of more than **308 mm [12 1/8 in]**, measured with the flat bar, provides easier steering but produces a wobbling effect at high speed.
- An adjustment of less than **308 mm [12 1/8 in]**, measured with the flat bar, results in harder steering and more stability at high speed.

NOTE: Once adjustment of the angle of attack on the front systems is completed, verify once again to confirm the adjustment.

ADJUSTMENTS

ANGLE OF ATTACK - REAR TRACK SYSTEMS

To obtain the correct angle of attack on rear Track Systems, perform the following:

RIGID AXLE OR TRAILING ARM SUSPENSION

CAUTION: Some vehicles require a particular adjustment. Refer to the *Installation Guidelines* specific to your vehicle model to confirm the adjustment.

- Stabilizing arm (1) must be attached to Track System and to rear anchor bracket (2) installed on vehicle. See Figure 10.

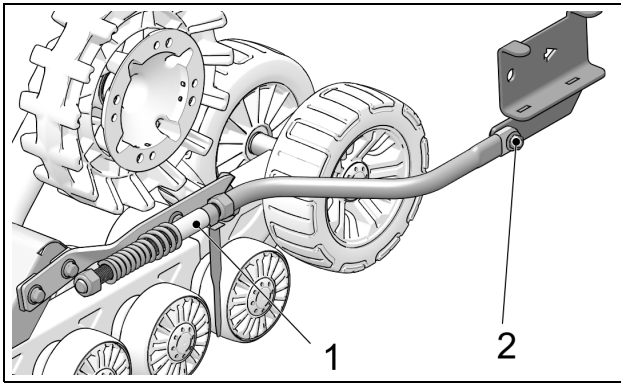

Figure 10

- Loosen the nut (3) compressing the spring of the stabilizing rod. See Figure 11.

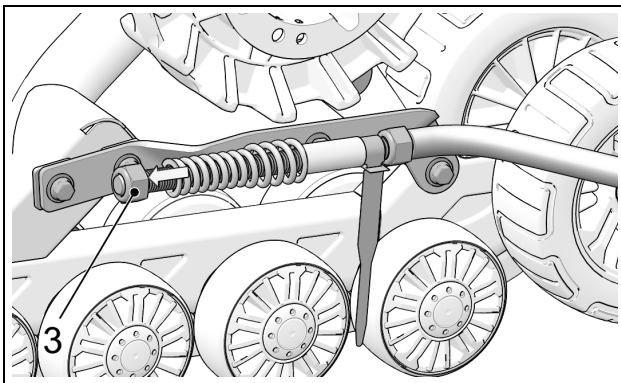

Figure 11

NOTE: Use the wide part of the adjusting template provided with the stabilizing arm to make the adjustment.

- Set the nut (4) to obtain a distance of 19 mm [3/4 in] between nut and stabilizing arm guide as shown on Figure 12.

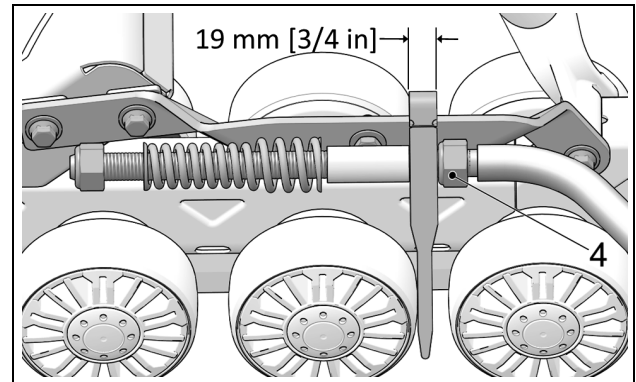

Figure 12

- Turn nut (3) until it comes in contact with the spring, then compress the spring by turning the nut 1 1/2 turns. See Figure 13.

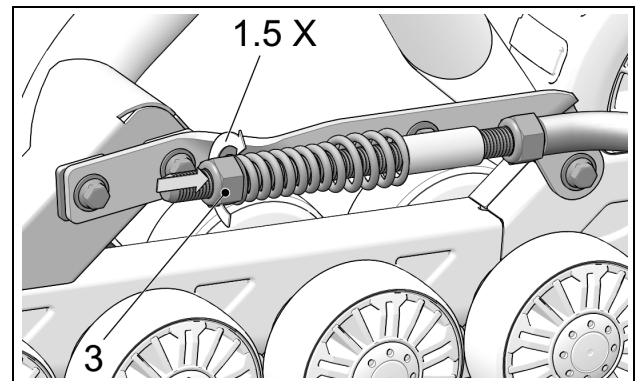

Figure 13

- **IMPORTANT:** Double-check the 19 mm minimum distance between nut and stabilizing arm guide. Re-adjust as needed. See Figure 14.

NOTE: Use the provided template to double-check the adjustment.

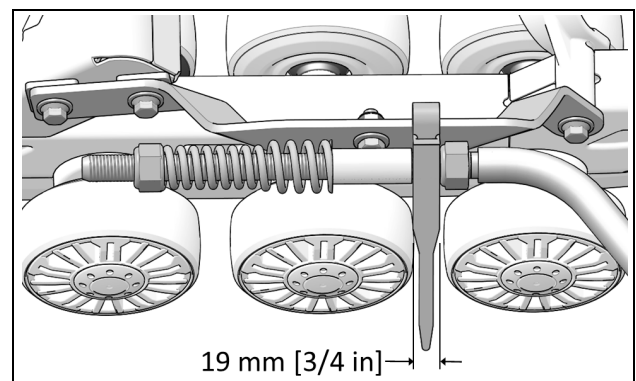

Figure 14

INDEPENDENT SUSPENSION (IS)

- Stabilizing arm (1) must be attached to the rear anchor bracket (2) installed on the vehicle. See Figure 15.

NOTE: Actual Rear Anchor bracket (2) installed on vehicle may differ from the one in the illustration.

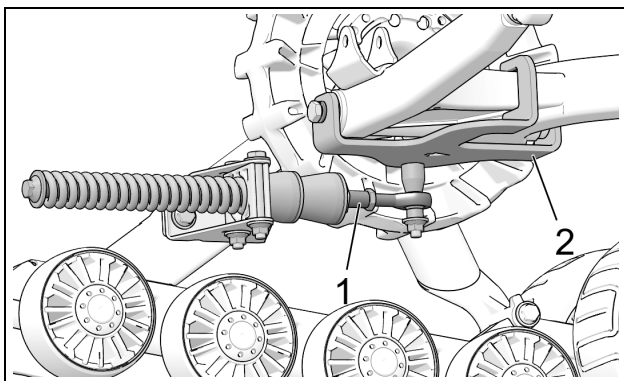

Figure 15

- Loosen anti-rotation bracket bolts (1) and (2) to allow the anti-rotation retainer (3) to rotate on its axis. See Figure 16.

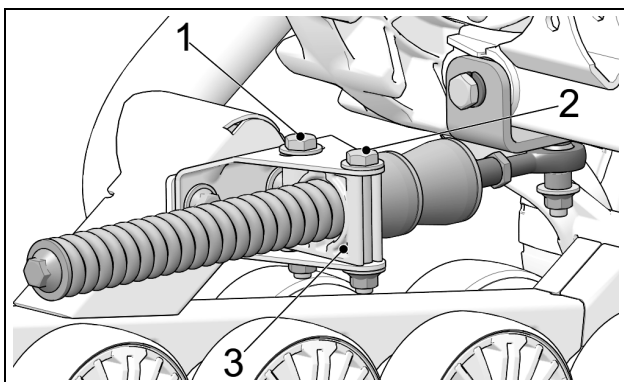

Figure 16

- Turn stabilizing arm nut to adjust length of rod end (1) and get rubber cone (2) to apply light pressure on anti-rotation retainer (3). Figure 17.

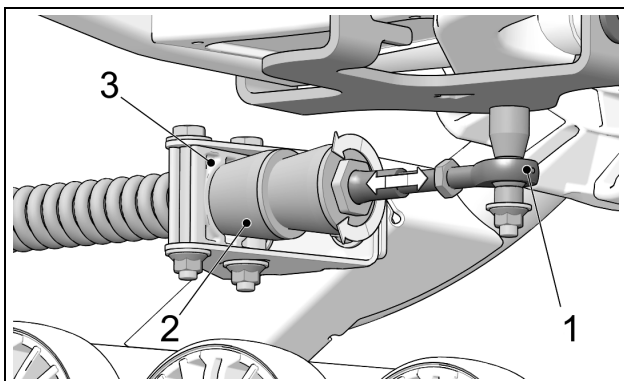

Figure 17

BASIC TUNING (Rear Track Systems):

- The adjustment is **incorrect** when the stabilizing arm's rubber cone is compressed and deformed. The stabilizing arm's spring is then difficult or impossible to turn by hand.
- Re-tighten jam nut (1) to 40 N•m [30 lb-ft] of torque when adjustment is complete. Figure 18.

CAUTION: Tighten the jam nut to the recommended torque specification. Overtightening the nut might damage the rod end.

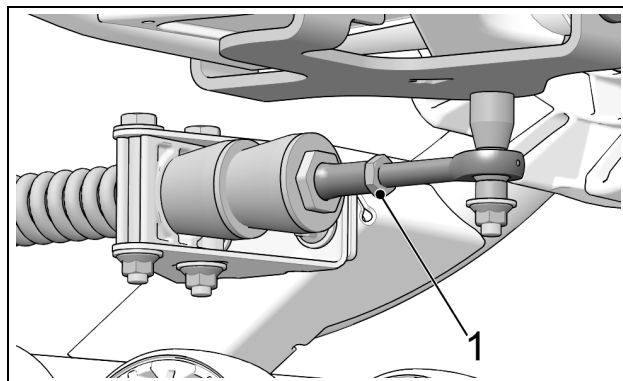

Figure 18

- Re-tighten anti-rotation bracket nuts (1) and (2) to 50 N•m [37 lb-ft] of torque. See Figure 19.

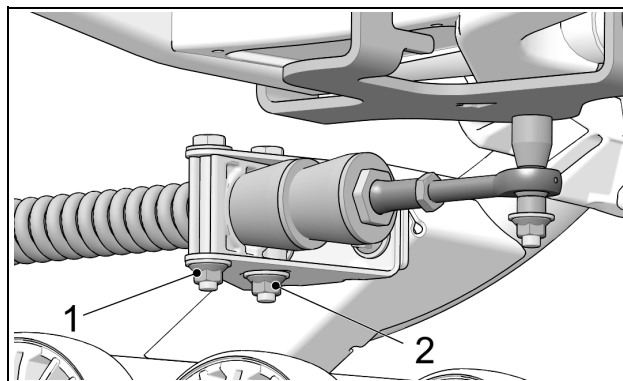

Figure 19

NOTE: Once adjustment of the angle of attack on rear systems is complete, verify once again to confirm the adjustment setting.

TRACK SYSTEM REMOVAL

CAUTION: Leaving the anti-rotation anchor brackets attached to the suspension arms, after having removed the Track Systems, could cause interference which might damage the vehicle. Remove all Track System anti-rotation mechanism components installed on the vehicle before reinstalling the wheels.

ADJUSTMENTS

ALIGNMENT

Parallelism must be adjusted with the SxS on the ground, driving the vehicle forward about 3 meters [10 ft.] and measuring toe-in distance. Refer to Figure 20.

NOTE: Every time the measurement has to be taken, drive in reverse, then, drive forward again on about 3 meters [10 ft.].

CAUTION: Verify condition of the steering system components before adjusting parallelism. Damaged components can prevent proper adjustment and impair proper operation of the system.

CAUTION: The parallelism adjustment of the front Track Systems is very important and is directly linked to the longevity of the system components. Users must follow attentively the adjustment and verification recommendations of this manual.

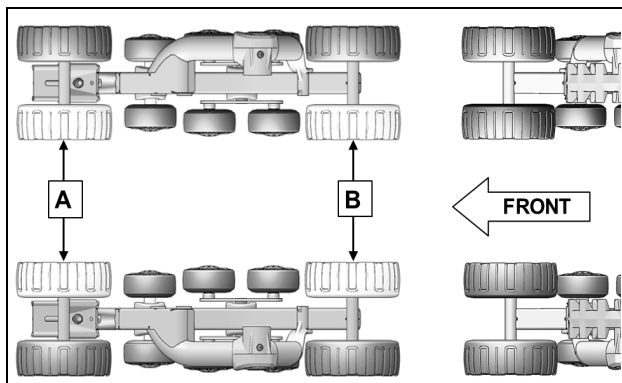

Figure 20

Dimension A: represents the distance between the inner front tires.

Dimension B: represents the distance between the inner back tires.

Dimension A must be equal to or greater than dimension B without exceeding 3 mm [1/8 inch].

A - B = 0 to 3 mm [1/8 inch]

Adjustment Method

To adjust the SxS's steering system, first loosen coupling rod nut (1), then screw or unscrew the coupling rod (2) an equal number of revolutions on both sides of the vehicle. See Figure 21.

NOTE: Starting with an open alignment setting provides a higher degree of precision in the adjustment.

CAUTION: Remember that some nuts have reverse threads before loosening a coupling rod nut (1) on the vehicle's steering system. Make sure to unlock the nut in the proper rotational direction.

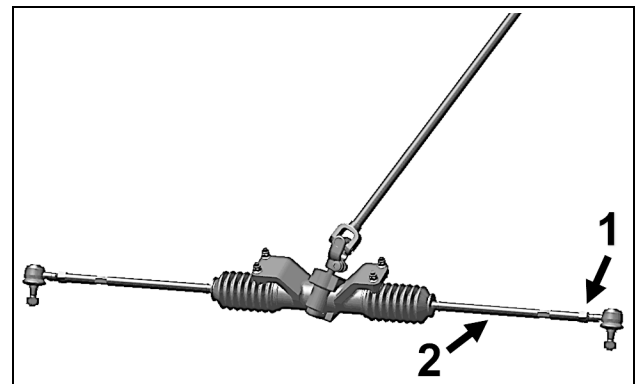

Figure 21

NOTE: Once the parallelism adjustment of the front Track Systems is completed, verify once more to confirm the adjustment setting.

Measure A: Measure the distance between the front inside Ø241 mm tires of the front Track Systems. See Figures 22, 23 and 24.

Measure B: Measure the distance between the rear inside Ø241 mm tires of the front Track Systems. See Figures 25, 26 and 27.

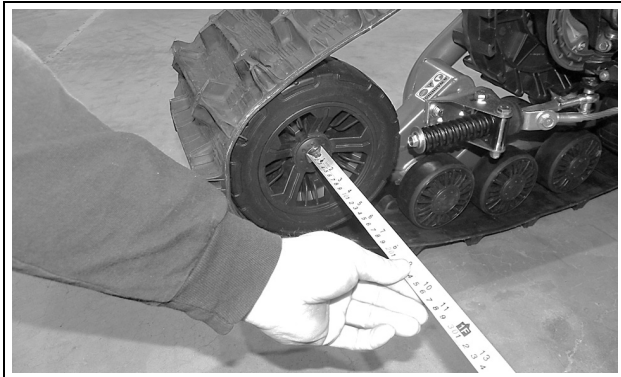

Figure 22

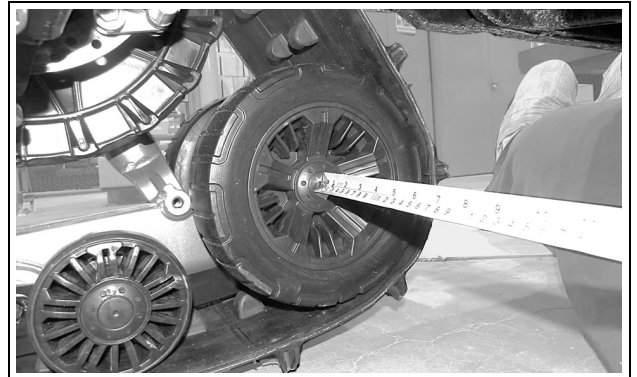

Figure 25

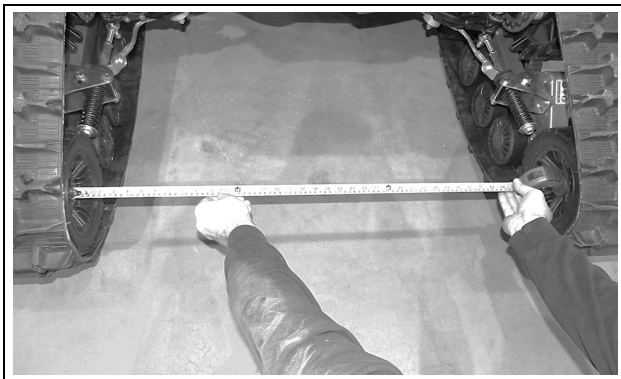

Figure 23 (Distance between the front tires)



Figure 26 (Distance between the rear tires)

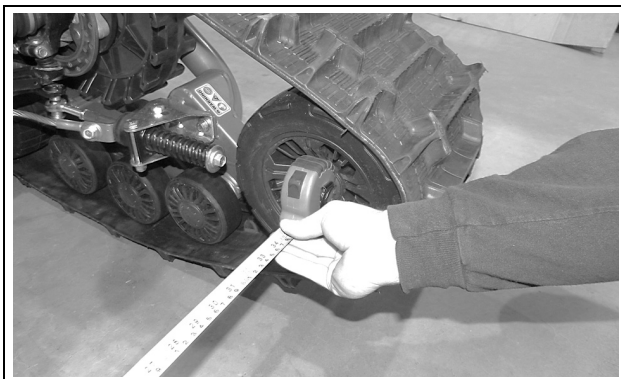

Figure 24



Figure 27

ADJUSTMENTS

RUBBER TRACK TENSION

CAUTION: The Track Tensioner assembly bolt must be loosened to adjust track tension.

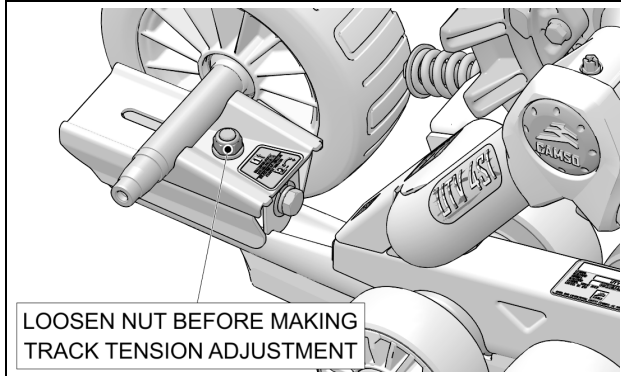

Figure 28

To adjust track tension, turn tension adjustment bolt clockwise or counterclockwise to obtain the recommended track tension. See Figure 29.

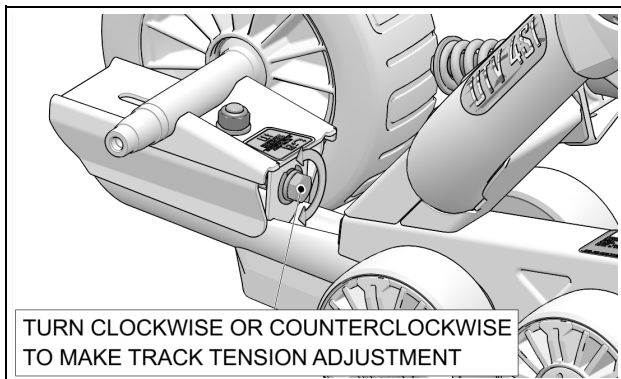

Figure 29

CAUTION: Make sure to re-tighten Track Tensioner assembly bolt after completing track tension adjustment.

The table below shows the force (1) applied and the deflection (2) which must occur to correctly set track tension. Refer also to Figure 31.

TRACK	FORCE	DEFLECTION
Front	13.5 kg [30 lb]	19 mm [¾ inch]
Rear	13.5 kg [30 lb]	19 mm [¾ inch]

BASIC TUNING

- A higher rubber track tension reduces the risk of “derailing” and reduces drive “ratcheting”.

NOTE: Track tension set too high could cause premature wear on system components and is therefore not recommended.

- A lower rubber track tension provides better traction, a smoother ride and better fuel economy.

NOTE: The track tension testing tool shown below in Figure 30 can be purchased through an authorized Camso dealer. The part number is 2000-00-3125.



Figure 30

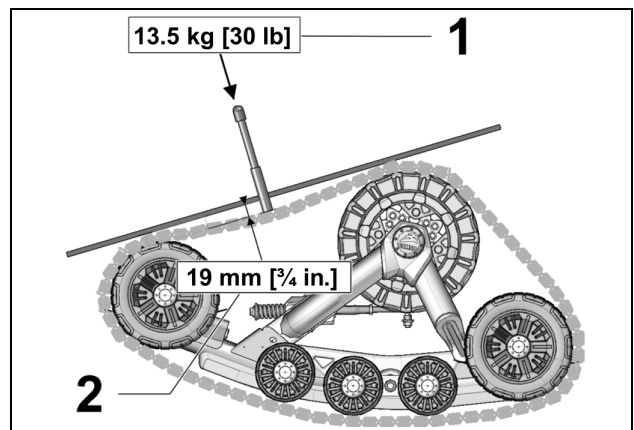

Figure 31

Final Check

Ride at slow speed on a distance of about 1.5 km [1 mile]. Re-adjust as required.

CAUTION: Minor installation problems could present themselves on some vehicles due to interference between system components and the vehicle. Refer to the section entitled “Completion” in the Installation Guidelines for instructions on how to work out these installation problems.

**CAMSO UTV 4S1 TRACK SYSTEMS
INSTALLATION AND ADJUSTMENT CHECKLIST**

**** Steps in this checklist are laid out in logical order. They should be performed in succession to optimize the track system installation on the vehicle. ****

1 - COMPONENT INSTALLATION

✓

A - INSTALLATION OF REAR ANCHOR

** Refer to INSTALLATION GUIDELINES section entitled "Rear track systems"*

B - INSTALLATION OF FRONT ANCHOR

** Refer to INSTALLATION GUIDELINES section entitled "Front track systems"*

C - INSTALLATION OF STEERING LIMITERS (if applicable)

** Refer to INSTALLATION GUIDELINES section entitled "Front track systems" . ** Do not adjust the Steering Limiter sets before having adjusted the angle of attack.*

2 - COMPONENT ADJUSTMENT

A - ANGLE OF ATTACK

** Refer to ADJUSTMENTS section entitled "Angle of attack"*

B - TRACK ALIGNMENT

** Refer to ADJUSTMENTS section entitled "Track alignment"*

C - TRACK TENSION

** Refer to ADJUSTMENTS section entitled "Track tension"*

D - STEERING LIMITER ADJUSTMENT (if applicable)

** Refer to INSTALLATION GUIDELINES section entitled "Front track systems"*

3 - INTERFERENCE CHECK

IN THE EVENT OF INTERFERENCE BETWEEN THE VEHICLE AND TRACK SYSTEM, SOME PARTS ON THE VEHICLE MAY HAVE TO BE REMOVED OR MODIFIED, OR A LIFT KIT MAY HAVE TO BE INSTALLED. IF APPLICABLE, SEE INSTALLATION GUIDELINES SECTION ENTITLED "COMPLETION".

4 - TEST RUN

1.5 km (1 mile) TEST RUN

5 - POST TEST RUN FINAL CHECKS

A - ANGLE OF ATTACK

** Refer to ADJUSTMENTS section entitled "Angle of attack"*

B - ALIGNMENT

** Refer to ADJUSTMENTS section entitled "Track alignment"*

C - TRACK TENSION

** Refer to ADJUSTMENTS section entitled "Track tension"*